



PIPE EQUIPMENT SPECIALISTS

PREP 16 PIPE BEVELLING 3" to 16"



SCAN QR CODE
TO WATCH VIDEO

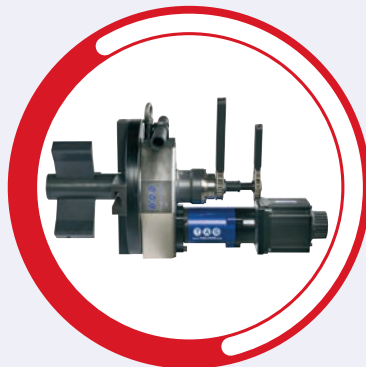

TAG **PREP 16**
Portable Pipe Beveling Machine

RANGE: 72 - 400mm i/d / 2.8 - 15.74" i/d

- **Functions:** External beveling
 Internal beveling
 Facing
 Counter-boring
 Weld removal
 J-prepping
 Compound bevels
- **Materials:** Any kind of steel and exotic alloy
- **Power:** Servo electric, pneumatic or hydraulic



FEATURES AND ADVANTAGES

The PREP 16 is the first in TAG's new range of a heavy duty mid-large diameter beveling machines.

Offering ratcheted i/d jaw locking as well as ratchet bevel feed control for effortless heavy wall preps, offered in extremely powerful user friendly servo electric or pneumatic any bevel geometry can be performed within the impressive 3" - 16" range.

J-preps, counter boring, and facing can all be performed, simultaneously, using the correct tooling fitted in (up to) 4 heavy duty hardened multi-position tool holders. Due to its light weight, yet unrivalled power, the PREP 16 is ideal for on-site, off shore, nuclear, and other applications where precision welds are required at an incredible value.

The PREP 16, and its bigger brother the PREP 24, utilise ratchet feed and locking. This allows effortless set-up, and enables the operator to deliver consistent feed with minimal effort.



 **MADE IN UK** 

POWER OPTIONS:

SERVO ELECTRIC

RECOMMENDED

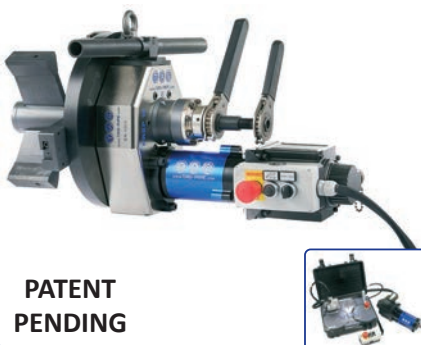

**PATENT
 PENDING**

PART NO. TP16SE110 / TP16SE220

PNEUMATIC



PART NO. TP16P

HYDRAULIC



PART NO. TP16H

FEATURES:

SELF-CENTERING

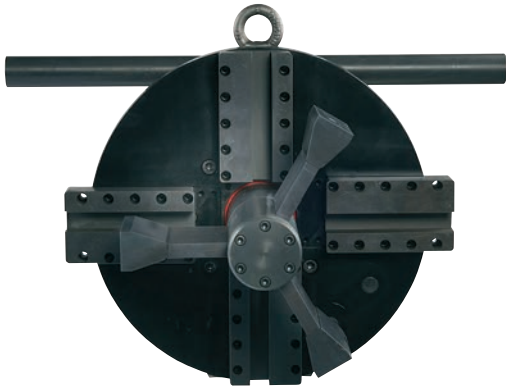

Self-centering 70mm (2.75") one piece locking shaft with built in jaws, eliminates the issue of broken or loosening retaining springs and o-rings.

UNRIVALLED POWER AND STABILITY



TAG innovative bearing/crown and pinion design combined with our large shaft, delivers unrivalled power and stability.

SERVO ELECTRIC



RECOMMENDED

**PATENT
PENDING**

SERVO ELECTRIC control box makes the strongest portable pipe beveling machine available on the market.

LIFTING HANDLES



To enable ease of set up, the machine is equipped with lifting handles and removable extensions so the machine can be easily installed, and removed from the pipe.

RATCHET FEED AND LOCKING



The PREP 16 has unrivalled power and stability, utilising a ratchet system for both jaw locking, and bevel feed.

SIX POINT LOCKING



Innovative wide locking jaws offer 6 point locking from 3 jaws giving superior clamping force for chatter free end preps.

PREP 16 TECHNICAL FEATURES

DESCRIPTION	MEASUREMENT	PNEUMATIC	SERVO ELECTRIC	HYDRAULIC
Part Number	n/a	TP16P	TP16SE110 / TP16SE220	TP16H
Locking tube range	mm / inch (i/d)	72 - 400 / 2.8 - 15.74"	72 - 400 / 2.8 - 15.74"	72 - 400 / 2.8 - 15.74"
Working range	mm / inch (o/d)	72 - 406 / 3 - 16"	72 - 406 / 3 - 16"	72 - 406 / 3 - 16"
Idle speed	rpm	5 - 18	1 - 18	1 - 26
Length of axial feed	mm / inch	50 / 2	50 / 2	50 / 2
Max operating temperature	°C	55	60	60
Max acoustic radiation	dB	75	45	55
Pneumatic Motor Power	hp	3.5	n/a	5.4
Air Consuming Flux	cfm / l/min.	90 / 2500	n/a	n/a
Air working pressure	psi / bar	90 / 6.5	n/a	n/a
Air Hose Connection	inches	¾"	n/a	n/a
Servo Electric Motor Power	kw	n/a	1.5	n/a
Voltage	volt	n/a	110 or 220	Refer to Hydraulic Power Pack
Frequency	Hz	n/a	50 / 60	Refer to Hydraulic Power Pack
Remote Control	Yes / No	No	Yes	Yes
Forward / Reverse	Yes / No	No	Yes	Yes
Unit weight	kg / lbs	43 / 95	44 / 97	41 / 90
Packing dimensions L x W x H	mm	860 x 570 x 530	860 x 570 x 530	860 x 570 x 530
Packing weight	kg / lbs	128 / 282	140 / 305	125 / 275

Our group policy is one of continuous improvement. Products and data tables are subject to change or vary from those illustrated.

- All units are supplied complete with all locking jaws to cover the full range of the machine. Service tools, drawings, instruction manual and warranty certificate are also supplied as standard.
- Each machine is supplied with a protective custom built box.
- Pneumatic machine must be used with filter lubricator and oil - use without will void warranty.



DIMENSIONS

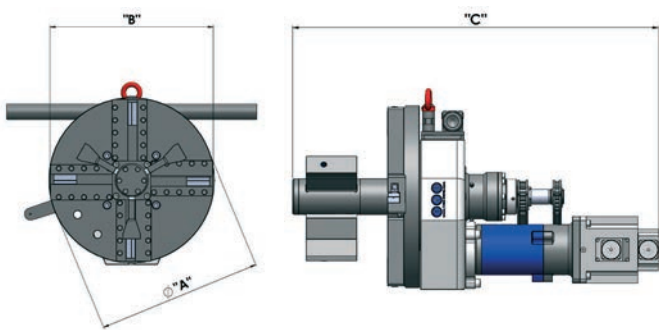

DIMENSIONS		PNEUMATIC	SERVO ELECTRIC	HYDRAULIC
ØA	mm	323	323	323
B	mm	407	407	407
C	mm	750	630	530

EXAMPLES OF COMMON CUTTING TOOLS

FORMED TOOLS

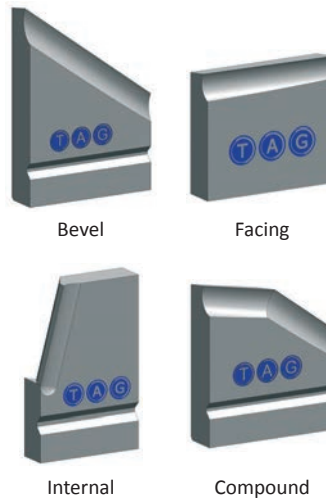

HOLDER / INSERT (Recommended)

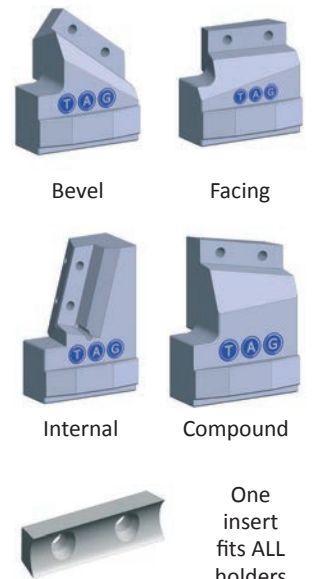

All shapes, sizes and angles available



PREP 16 AND PREP 24 ELBOW / FITTINGS

Portable Elbow and Fitting Machine

The TAG PREP 16 ELBOW / FITTINGS and TAG PREP 24 ELBOW / FITTINGS complete machine enables bevelling, J-preps, counter boring and facing on elbows and pipe fittings, due to its heavy duty yet compact shaft and 6 piece locking jaw system. The machines can be supplied in either servo electric, pneumatic or hydraulic.

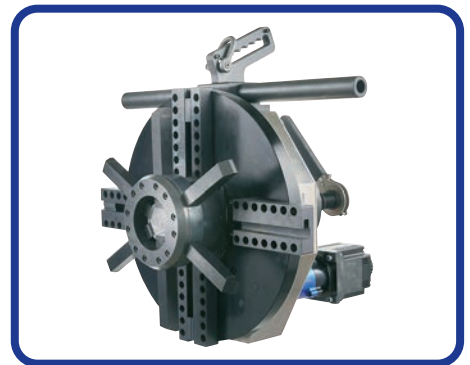

PREP 16 AND PREP 24 ELBOW / FITTINGS TECHNICAL FEATURES

DESCRIPTION	MEASUREMENT	PNEUMATIC	SERVO ELECTRIC	HYDRAULIC
Part Number	n/a	TP16EP	TP16ESE110 / TP16ESE220	TP16EH
Locking tube range	mm / inch (i/d)	130 - 410mm / 5.11 - 16.14"	130 - 410mm / 5.11 - 16.14"	130 - 410mm / 5.11 - 16.14"
Part Number	n/a	TP24EP	TP24ESE110 / TP24ESE220	TP24EH
Locking tube range	mm / inch (i/d)	210 - 600mm / 8.26 - 23.62"	210 - 600mm / 8.26 - 23.62"	210 - 600mm / 8.26 - 23.62"

DIMENSIONS PREP 16/24 ELBOW / FITTINGS

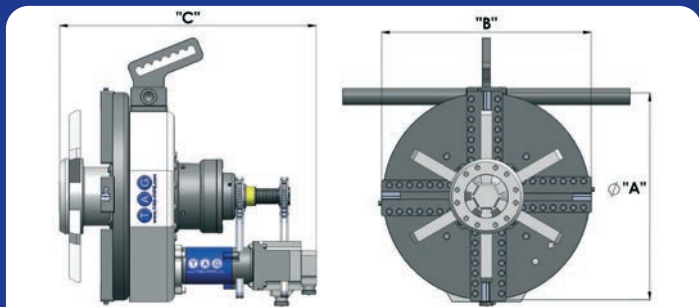

	DIMENSIONS		PNEUMATIC	SERVO ELECTRIC	HYDRAULIC
PREP 16	ØA	mm	323	323	323
	B	mm	407	407	407
	C	mm	705	650	550
PREP 24	ØA	mm	550	550	550
	B	mm	580	580	580
	C	mm	755	705	605

EXAMPLES OF FITTINGS

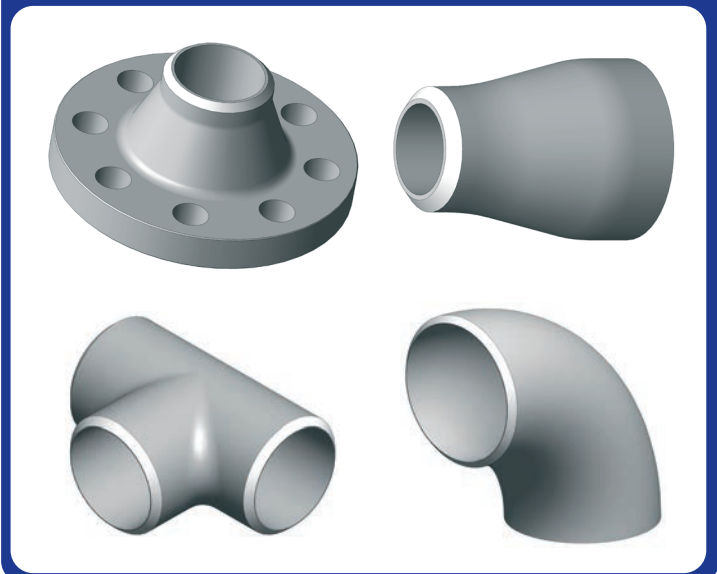



SPECIALIZED FABRICATION EQUIPMENT GROUP

Global Locations:



United States:

SFE HOUSTON

SPECIALIZED FABRICATION EQUIPMENT GROUP

4433 South Dr, Houston,
Texas 77053, USA

Tel: +1 713 747 8502

E-mail: sales@sfe-brands.com

SFE TULSA

SPECIALIZED FABRICATION EQUIPMENT GROUP

7136 South Yale Ave, Tulsa,
Oklahoma 74136, USA

Tel: +1 713 747 8502

E-mail: sales@sfe-brands.com

International:

SFE UNITED KINGDOM

SPECIALIZED FABRICATION EQUIPMENT GROUP

Unit 15 & 16 Grendon Industrial Estate,
Grendon Underwood, Aylesbury,
Buckinghamshire, HP18 0QX England

Tel: +44 (0)1869 324 144

E-mail: sales-int@sfe-brands.com

SFE BELGIUM

SPECIALIZED FABRICATION EQUIPMENT GROUP

Mosten 13, 9160 Lokeren
Belgium

Tel: +44 (0)7741 551536

E-mail: sales-belgium@sfe-brands.com

SFE FRANCE

SPECIALIZED FABRICATION EQUIPMENT GROUP

Acces bureau, 34 Rue du Docteur Abel,
26000 VALENCE, France

Tel: +44 (0)7741 872489

E-mail: sales-france@sfe-brands.com

SFE GERMANY

SPECIALIZED FABRICATION EQUIPMENT GROUP

Am Güterbahnhof 1, 77694 Kehl am Rhein,
Germany

Tel: +49 (0)7851 9553507

Mob: +44 (0)7741 872489

E-mail: sales-germany@sfe-brands.com

SFE MIDDLE EAST

SPECIALIZED FABRICATION EQUIPMENT GROUP

Al Ittihad Street, P.O. Box 3763
Dubai, United Arab Emirates

Tel: +971 (0)50 217 1376

E-mail: sales-me@sfe-brands.com

SFE INDIA

SPECIALIZED FABRICATION EQUIPMENT GROUP

Plot No. PAP 3, D 3 Block,
Chinchwad, Pune 411 019

Mob: +91 90 1102 4332

Mob: +91 95 5258 4361

E-mail: sales-india@sfe-brands.com

SFE ASIA

SPECIALIZED FABRICATION EQUIPMENT GROUP

Emerald Block A, No.2, Road N4, Son Ky Ward,
Tan Phu District, Ho Chi Minh, Vietnam.

Tel: 0919.517.01

E-mail: sales-asia@sfe-brands.com

Copyright © 2021 Specialized Fabrication Equipment Group, All rights reserved.

OUR BRANDS



PIPE EQUIPMENT SPECIALISTS

